



# Technical Specification

Push Switch with interlock function

Switch: „ Flood light TOP “

Pneutron-Part No.: 11165080XX

AGCO Fendt No.: G312.900.160.010 / G312.900.160.011

Connector 6,3 x 0,8

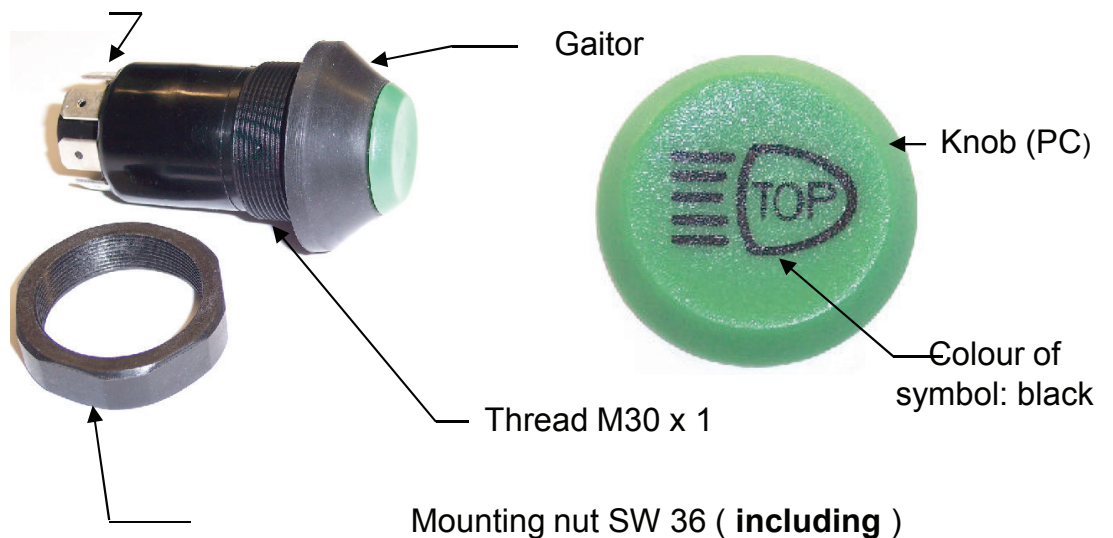

Knob with symbol „Flood light TOP“ (Part No.):

11346390XX

Knob Colour:

green ( matt )

Symbol – Colour:

black

Illumination lamp:

12V 1,2W

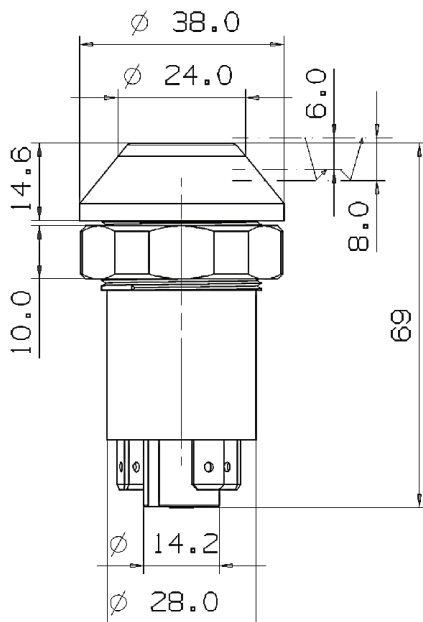

Connectors

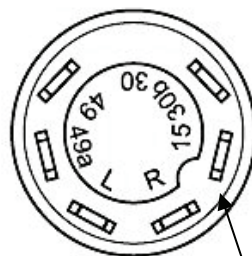

Pins 6,3 x 0,8

Circuit diagram

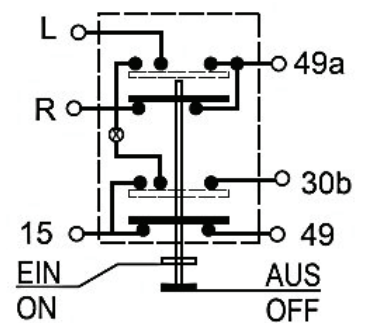

mit Arretierung  
with locking